

Triton Barrier[®]

For TL-1, TL-2, TL-3 Applications

Product Description Manual

Part No. 619487B

Revision F July 2012



TRINITY
HIGHWAY PRODUCTS
ENERGY ABSORPTION SYSTEMS

Triton Barrier[®] For TL-1, TL-2, TL-3 Applications

Product Description Manual



Important: These instructions are to be used only in conjunction with the assembly, maintenance, and repair of the Triton Barrier[®] system. These instructions are for standard assemblies specified by the appropriate highway authority only. In the event the specified system assembly, maintenance, or repair would require a deviation from standard assembly parameters, contact the appropriate highway authority engineer. This system has been accepted for use by the Federal Highway Administration for use on the national highway system under strict criteria utilized by that agency. Energy Absorption Systems representatives are available for consultation if required.

This Manual must be available to the worker overseeing and/or assembling the product at all times. For additional copies, contact Energy Absorption Systems at (888) 323-6374 or download from websites below.

The instructions contained in this Manual supersede all previous information and Manuals. All information, illustrations, and specifications in this Manual are based on the latest Triton Barrier[®] system information available to Energy Absorption Systems at the time of printing. We reserve the right to make changes at any time. Please contact Energy Absorption Systems to confirm that you are referring to the most current instructions.

Table of Contents

Customer Service Contacts	3
Important Introductory Notes	3
Recommended Safety Rules for Assembly	4
Safety Symbols	5
Warnings and Cautions.....	5
Limitations and Warnings.....	6
Important Introductory Notes	7
Construction.....	8
General Information	10
Length of Need	16
Deflection/Clear Zone	18
End Treatment	20
End Treatment Configuration.....	24
Other Considerations	27

Customer Service Contacts

Energy Absorption Systems (a Trinity Highway Products company) is committed to the highest level of customer service. Feedback regarding the Triton Barrier® system, its assembly procedures, supporting documentation, and performance is always welcome. Additional information can be obtained from the contact information below:

Energy Absorption Systems:

Telephone:	(888) 323-6374 (USA Only) (312) 467-6750 (USA or International)
E-mail:	customerservice@energyabsorption.com
Internet: Energy Absorption Systems Trinity Highway Products, LLC Trinity Industries, Inc.	http://www.energyabsorption.com http://www.highwayguardrail.com http://www.trin.net

Important Introductory Notes

Proper assembly of the Triton Barrier® system is essential to achieve performance of the system under appropriate federal and state criteria. These instructions should be read in their entirety and understood before assembling the Triton Barrier® system. These instructions are to be used only in conjunction with the assembly of the Triton Barrier® system and are for standard assemblies only as specified by the applicable highway authority. In the event your system assembly requires or involves deviation from standard parameters or, during the assembly process a question arises, please contact the appropriate highway authority that specified this system at this particular location for guidance. Energy Absorption Systems is available for consultation with that agency. These instructions are intended for an individual who is qualified to both read and accurately interpret them as written. They are intended for the individual who is experienced and skilled in the assembly of highway products which are specified and selected by the highway authority.

A set of product and project shop drawings are available from Energy Absorption Systems. The shop drawings will be for each section of the assembly. These drawings should be reviewed and studied thoroughly by a qualified individual who is skilled in interpreting them before the start of any assembly.



Important: Read safety instructions thoroughly and follow the assembly directions and suggested safe practices before assembling, maintaining, or repairing the Triton Barrier[®] system. Failure to follow this warning can result in serious injury or death to the worker and/or bystanders. It further compromises the acceptance of this system by the FHWA. Please keep these instructions for later use.



Warning: Ensure that all of the Triton Barrier[®] system Warnings, Cautions, and Important statements within the Triton Barrier[®] Manual are completely followed. Failure to follow this warning could result in serious injury or death in the event of a collision.

Recommended Safety Rules for Assembly

*** Important Safety Instructions ***

This Manual must be kept in a location where it is readily available to persons who are skilled and experienced in the assembly, maintenance, or repair of the Triton Barrier[®] system. Additional copies of this Manual are immediately available from Energy Absorption Systems by calling (888) 323-6374 or by email at customerservice@energyabsorption.com. This Manual may also be downloaded directly from the websites indicated below. Please contact Energy Absorption Systems if you have any questions concerning the information in this Manual or about the Triton Barrier[®] system.

Always use appropriate safety precautions when operating power equipment and when moving heavy equipment or the Triton Barrier[®] components. Gloves, safety goggles, steel toe boots, and back protection shall be used.

Safety measures incorporating traffic control devices specified by the highway authority must be used to provide safety for personnel while at the assembly, maintenance, or repair site.

Safety Symbols

This section describes the safety symbols that appear in this Triton Barrier® Manual. Read the Manual for complete safety, assembly, operating, maintenance, repair, and service information.

<u>Symbol</u>	<u>Meaning</u>
---------------	----------------



Safety Alert Symbol: Indicates Danger, Warning, or Caution. Failure to read and follow the Danger, Warning, Safety, or Caution indicators could result in serious injury or death to the workers and/or bystanders.

Warnings and Cautions

Read all instructions before assembling, maintaining, or repairing the barrier system.



Warning: Do not assemble, maintain, or repair the barrier system until you have read this Manual thoroughly and completely understand it. Ensure that all Warnings, Cautions and Important statements within the Manual are completely followed. Please call Energy Absorption Systems at (888) 323-6374 if you do not understand these instructions. Failure to follow this warning could result in serious injury or death in the event of a collision.



Warning: Safety measures incorporating appropriate traffic control devices specified by the highway authority must be used to protect all personnel while at the assembly, maintenance, or repair site. Failure to follow this warning could result in serious injury or death in the event of a collision.



Warning: Use only Energy Absorption Systems parts that are specified herein for the Triton Barrier® for assembling, maintaining, or repairing the Triton Barrier® system. Do not utilize or otherwise comeingle parts from other systems even if those systems are other Energy Absorption Systems or Trinity Highway Products systems. Such configurations have not been tested, nor have they been accepted for use. Assembly, maintenance, or repairs using unspecified parts or accessories is strictly prohibited. Failure to follow this warning could result in serious injury or death in the event of a vehicle impact with an UNACCEPTED system.



Warning: Do NOT modify the barrier system in any way. Failure to follow this warning could result in serious injury or death in the event of a collision.



Warning: Ensure that the barrier system and delineation used meet all federal, state, specifying agency, and local specifications. Failure to follow this warning could result in serious injury or death in the event of a collision.



Warning: Ensure that your assembly meets all appropriate Manual on Uniform Traffic Control Devices (MUTCD) and local standards. Failure to follow this warning could result in serious injury or death in the event of a collision.

Limitations and Warnings

Energy Absorption Systems, in compliance with the National Cooperative Research Highway Program 350 (NCHRP Report 350) “Recommended Procedures for the Safety Performance of Highway Safety Features”, contracts with FHWA approved testing facilities to perform crash tests, evaluation of tests, and submittal of results to the Federal Highway Administration for review.

The Triton Barrier[®] system was tested to meet the impact criteria, requirements and guidelines of NCHRP Report 350. These tests, specifically set forth by FHWA, evaluate product performance by simulating those impacts outlined by NCHRP Report 350 involving a typical range of vehicles on our roadways, from lightweight cars (approx. 820kg [1800 lb.]) to full size pickup trucks (approx. 2000 kg [4400 lb.]) as specified by the FHWA. A product can be certified for multiple Test Levels. The Triton Barrier[®] is certified to the Test Level(s) as shown below:

Test Level I: 50 km/h [31 mph]
Test Level II: 70 km/h [45 mph]
Test Level III: 100 km/h [62 mph]

These FHWA directed tests are not intended to represent the performance of systems when impacted by every vehicle type or every impact condition existing on the roadway. This system is tested only to the test matrix criteria of NCHRP 350 as approved by FHWA.

Energy Absorption Systems does not represent nor warrant that the results of these controlled tests show that vehicle impacts with the products in other conditions would necessarily avoid injury to person(s) or property. Impacts that exceed the specifications of the system may not result in acceptable crash performance as outlined in NCHRP Report 350, relative to structural adequacy, occupant risk and vehicle trajectory. Energy Absorption Systems expressly disclaims any warrant or liability for injury or damage to persons or property resulting from any impact, collision, or harmful contact with products, other vehicles, or nearby hazards or objects by any vehicle, object or person, whether or not the products were assembled by or in the presence of Energy Absorption Systems representatives or by third parties.

The Triton Barrier[®] system is intended to be deployed, delineated, and maintained in accordance with specific state and federal guidelines. However, the material is only intended to supplement delineation required by the Department of Transportation’s “Manual on Uniform Traffic Control Devices” (MUTCD). Design tables are provided in this Manual to aid in selecting the most appropriate product configuration for proper application to the site. The appropriate highway authority approved engineer should be careful to properly select, assemble, and maintain the product. Careful evaluation of the site geometry, vehicle population type, speed, traffic direction and visibility are some of the elements that require evaluation for the proper selection of a safety appurtenance by the appropriate specifying highway authority.

After an impact occurs, the product must be repaired to its original condition as soon as possible. When a safety product is impacted, it is mandatory that the highway authority inspect all the components for damage and replace/repair components as necessary. If the system is not repairable, a complete system replacement is required.

Important Introductory Notes

Proper deployment and maintenance of the Triton Barrier® system is critical to achieve performance under appropriate state and federal guidelines. Take the time to review this Manual, including the Limitations and Warnings, section thoroughly before performing the necessary work. Do not attempt to assemble any longitudinal Triton Barrier® without the proper plans and assembly Manual from the manufacturer.

If you require additional information, or have questions about the Triton Barrier®, please contact Energy Absorption Systems Customer Service Department. See Customer Service Contacts on Page 3 of this Manual.

Construction

A Triton Barrier® assembly is constructed from a series of individual barrier sections. See Figures 1 & 2 for approximate physical dimensions, capacities and items included with each section.

Triton Barrier® sections are available in white and work zone safety orange colors. Each section is constructed of a lightweight polyethylene plastic shell intended to accept water ballast. This durable, recyclable material resists cracking, breakage and corrosion under harsh environmental conditions.

The plastic shell is strengthened by an internal steel framework to provide additional rigidity during handling and impacts. A steel cable, provided along a recess in the top of the section, resists the tensile forces generated during high severity impacts.

The ends of each section are constructed with knuckles that interlock with those of other segments. The end knuckles are vertically aligned to accept a Steel Connecting Pin. The pin securely joins the sections and the Tension Cables for maximum impact performance. The sections can swivel 9.7 deg. at the pin for easy positioning around work areas. The sections can be positioned with an inside radius as small as 11.3 m (37').

Triton Barrier® is constructed in a unique shape. The inwardly sloping ribbed sidewalls have been shown to interact with an impacting vehicle in a way that resists penetration, underriding, or an untested effect on the impacting vehicle, if such vehicle impacts within those criteria set forth by the FHWA. Sections are also stackable to reduce shipping and storage space.

Each Triton Barrier® section is constructed with fork lift ports to allow for mechanical lifting if desired. Large fill openings and a rapid release Gate Valve are provided to allow quick filling or draining of the water ballast. A permanent fill level indicator in the top of each section allows quick verification that the section is adequately full.

The Triton Barrier® TL-3 (for 100 km/h [62 mph] specified speed) includes two Pedestals. The Pedestal is made from lightweight polyethylene and is strapped to the forklift ports. The Triton Barrier® TL-3 (for 100 km/h [62 mph]) End Treatment uses a Short Steel Pedestal that is made from steel and bolted to the last section.

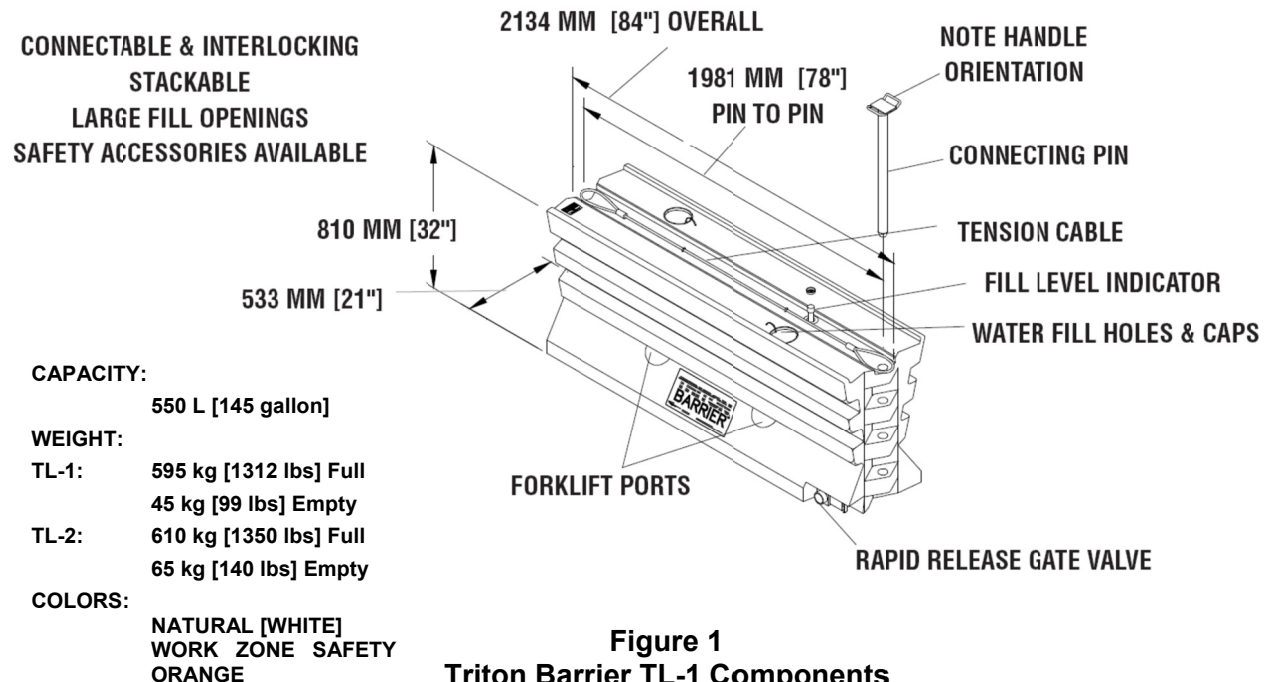
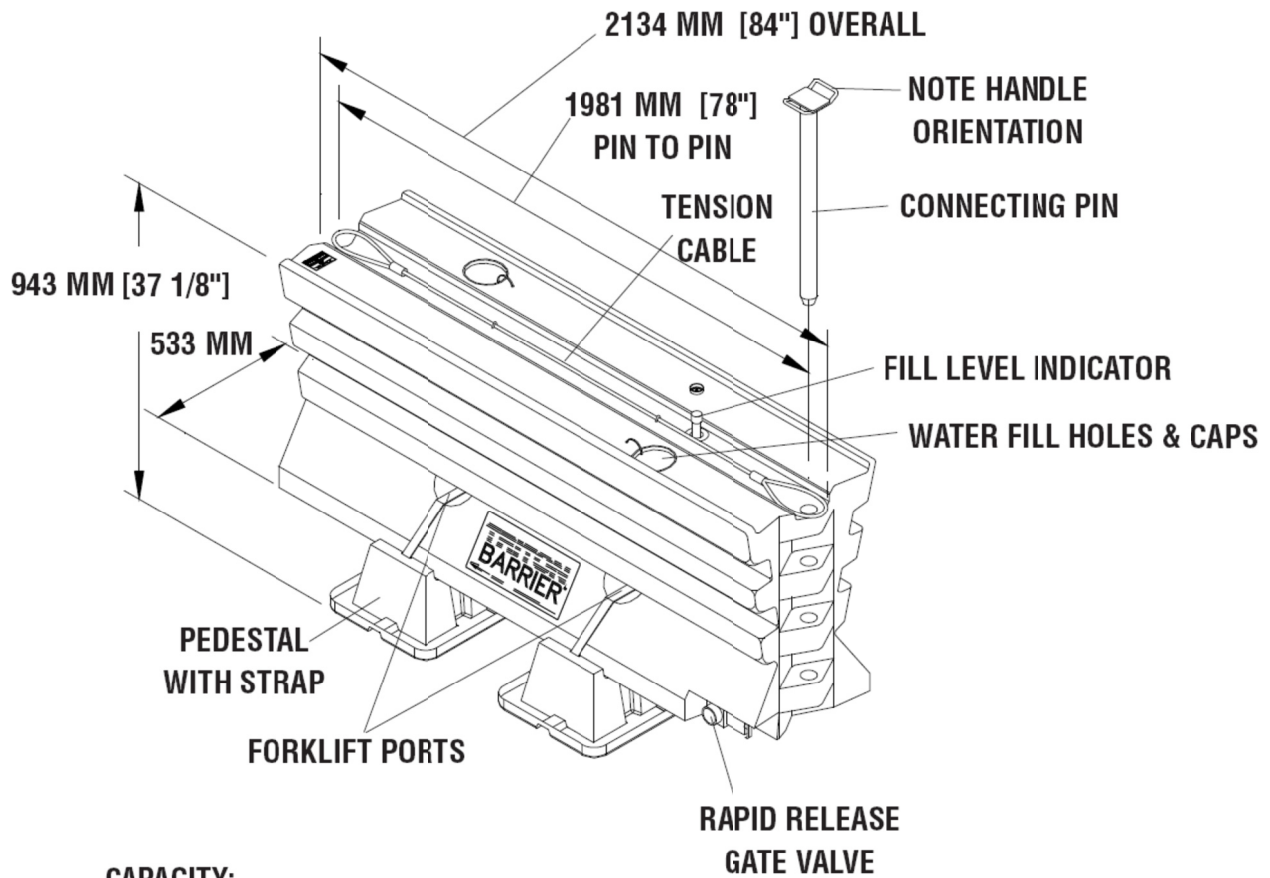

Figure 1
Triton Barrier TL-1 Components
Triton Barrier TL-2 Components

**CONNECTABLE & INTERLOCKING
STACKABLE
LARGE FILL OPENINGS
SAFETY ACCESSORIES AVAILABLE**



CAPACITY:

550L [145 GAL.]

WEIGHT:

610 KG [1350 LBS] FULL

65 KG [140 LBS] EMPTY

COLORS:

NATURAL [WHITE]

WORK ZONE SAFETY ORANGE

**Figure 2
Triton Barrier® TL-3 Components**

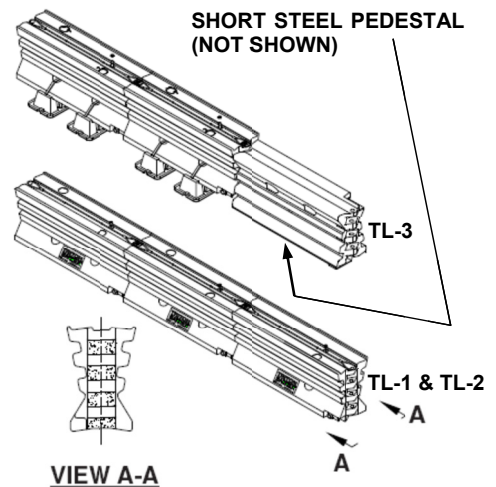

**Figure 3
Triton Barrier Assembly**

General Information

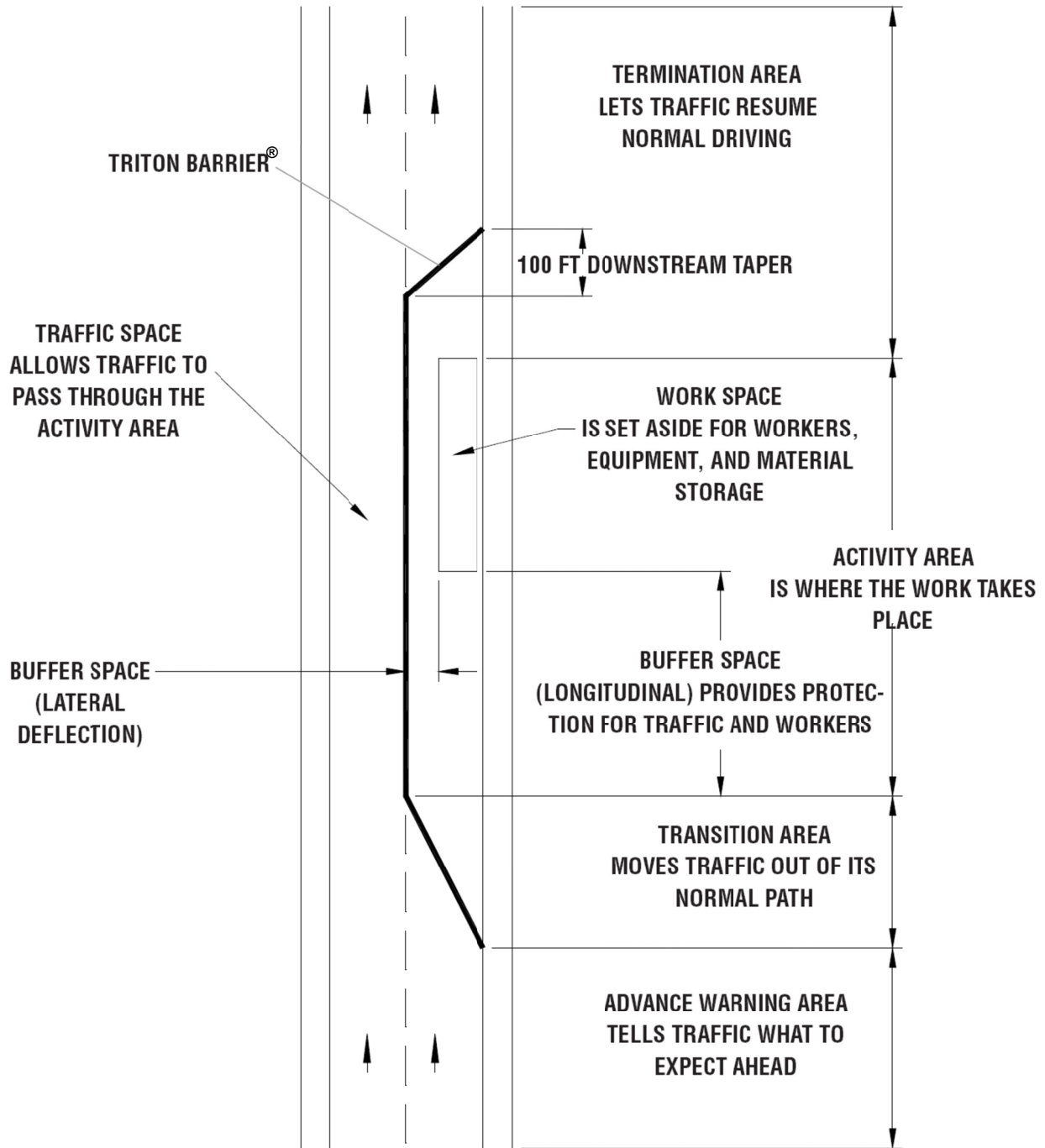

Figure 4
Reference MUTCD-Part 6 Figure 6C-1

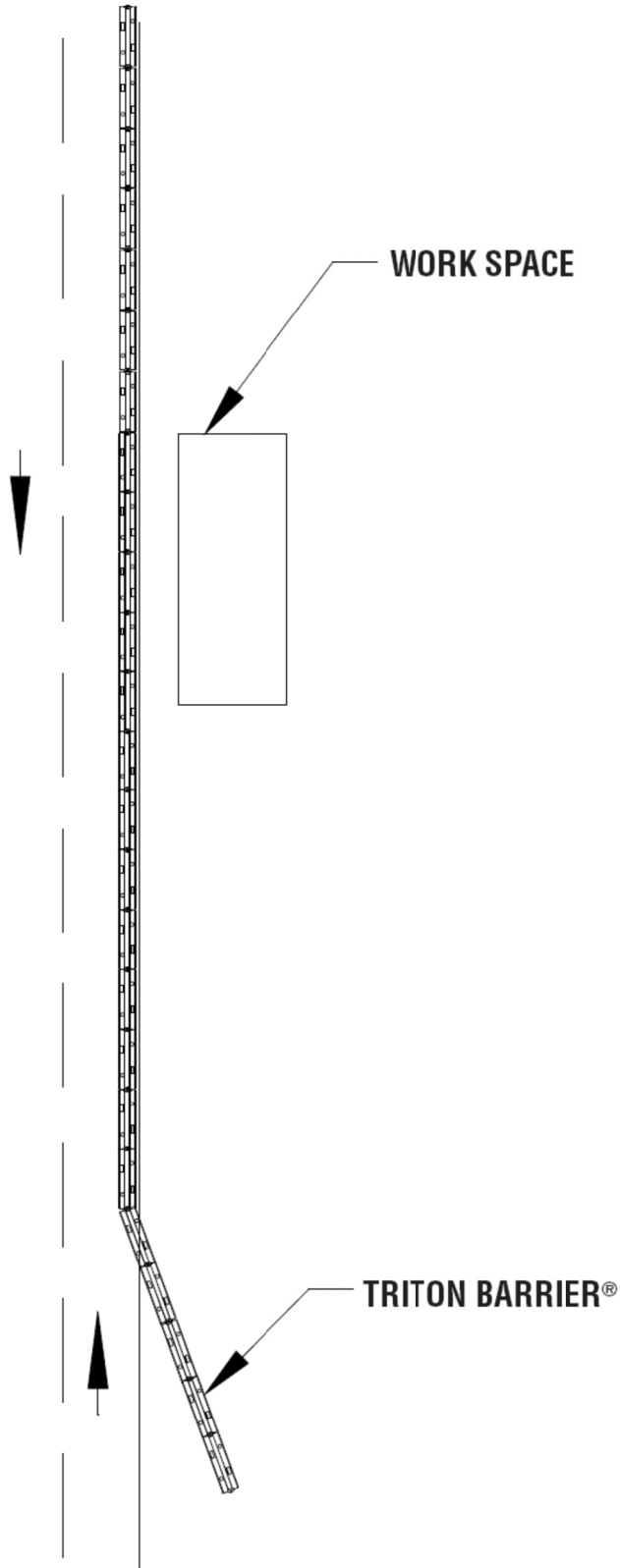

Figure 5
Shoulder work with Minor Encroachment
 (Similar to TA-3, TA-5 and TA-6 of
 MUTCD Part 6)

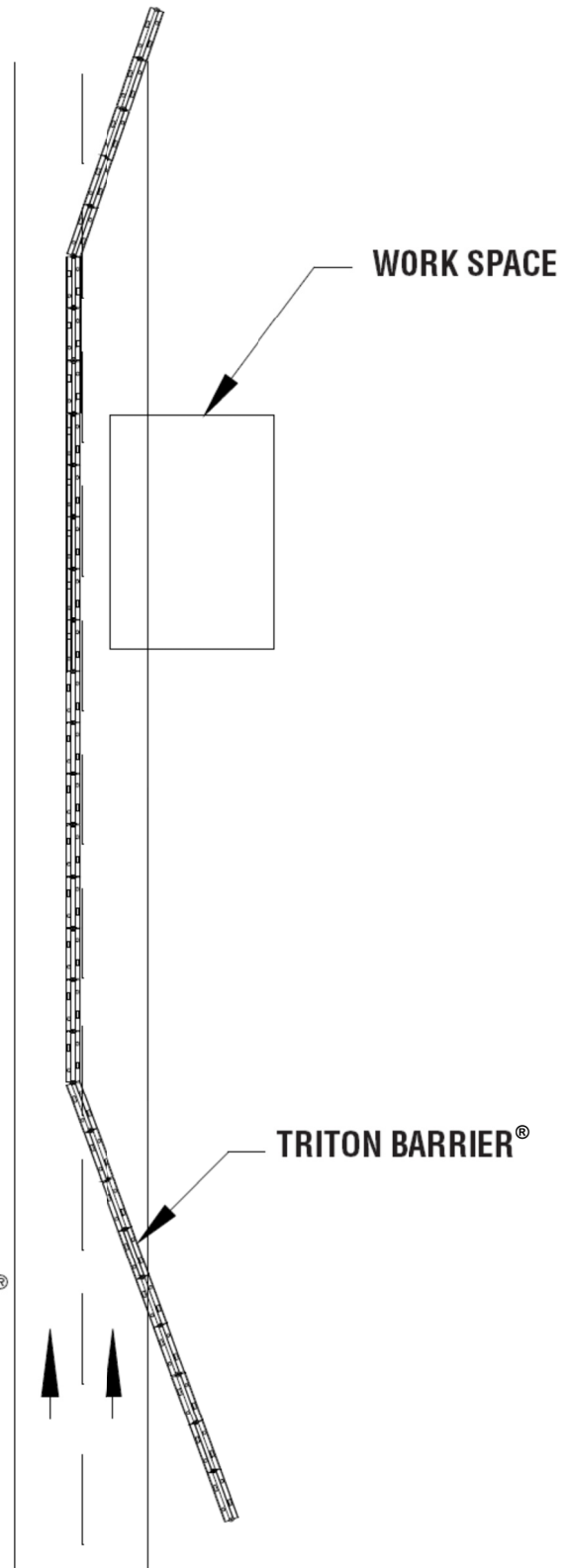

Figure 6
One Lane and Shoulder Closure
 (Similar to TA-11, TA-18, TA-33 and
 TA-34 of MUTCD Part 6)

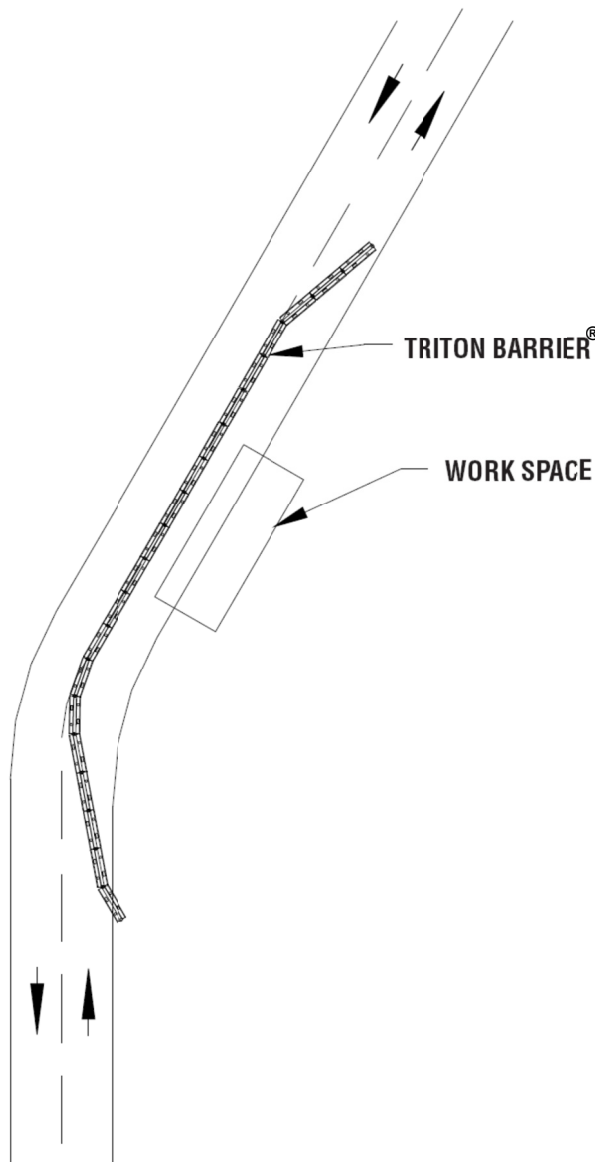

Figure 7
Lane Closure for One Lane-Two Way
Traffic Control (Similar to Figure 6C-3
And TA-10 of MUTCD Part 6)

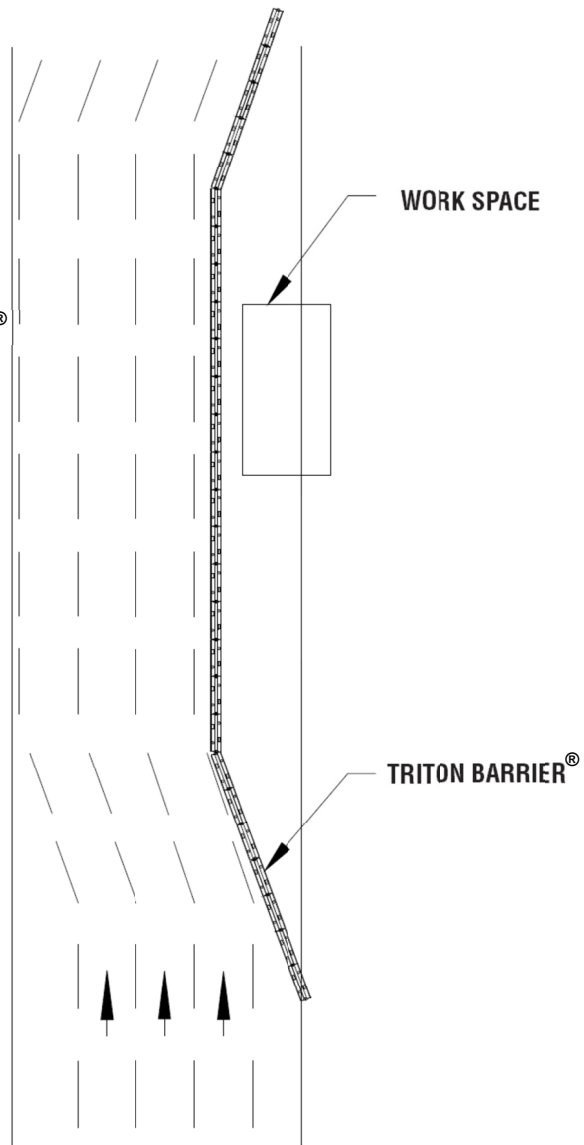

Figure 8
Lane Shift on Freeway
(Similar to TA-36 of MUTCD Part 6)

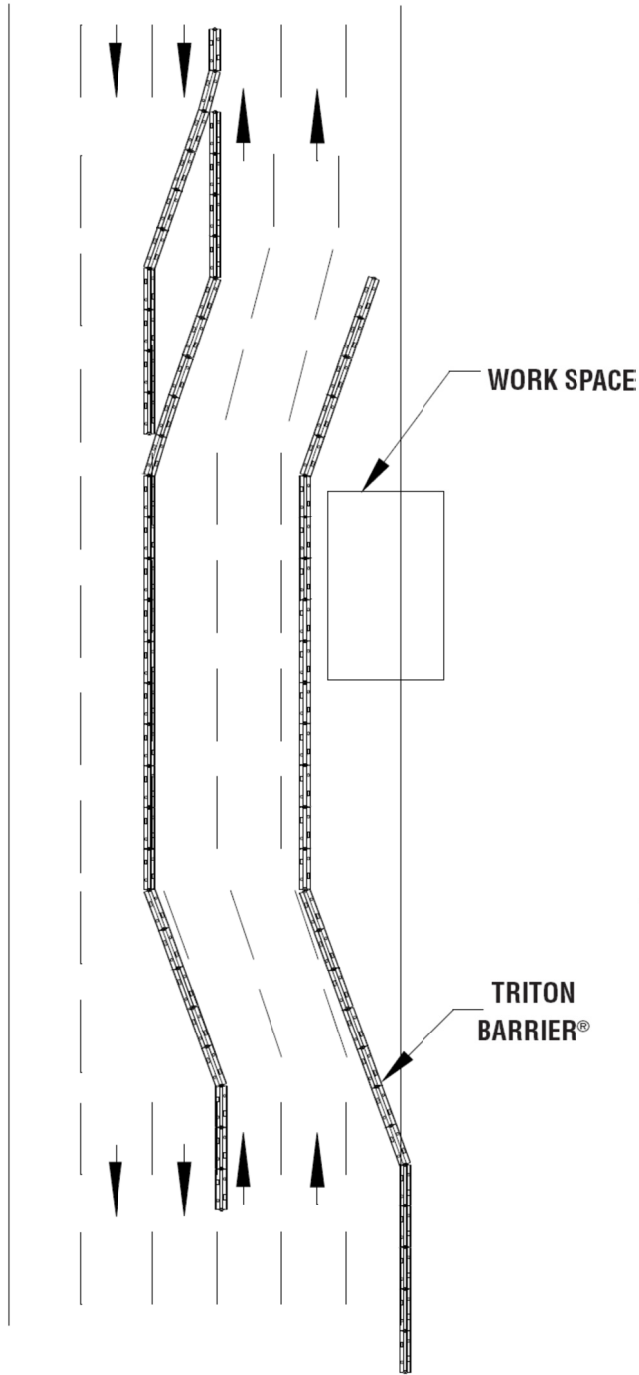

Figure 9
Taper and Buffer Space (Similar to Figure 6C-2 and TA-32 of MUTCD Part 6)

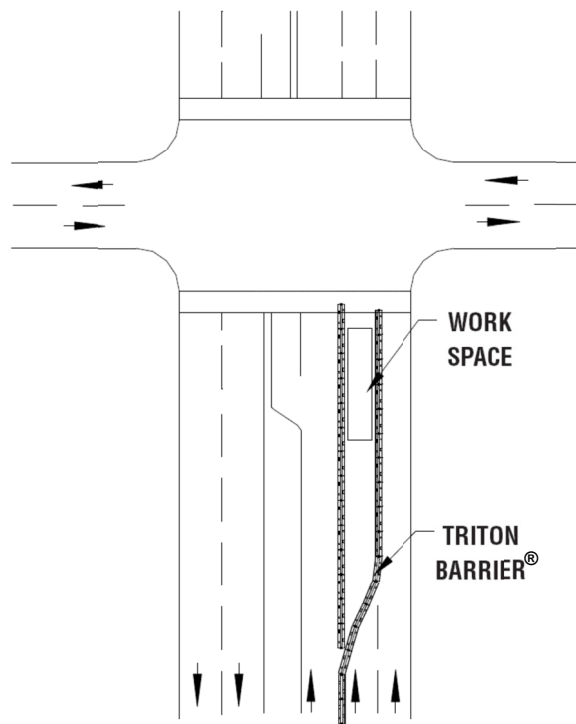

Figure 10
Lane Closure Near Side of Intersection (Similar to TA-21 of MUTCD Part 6)

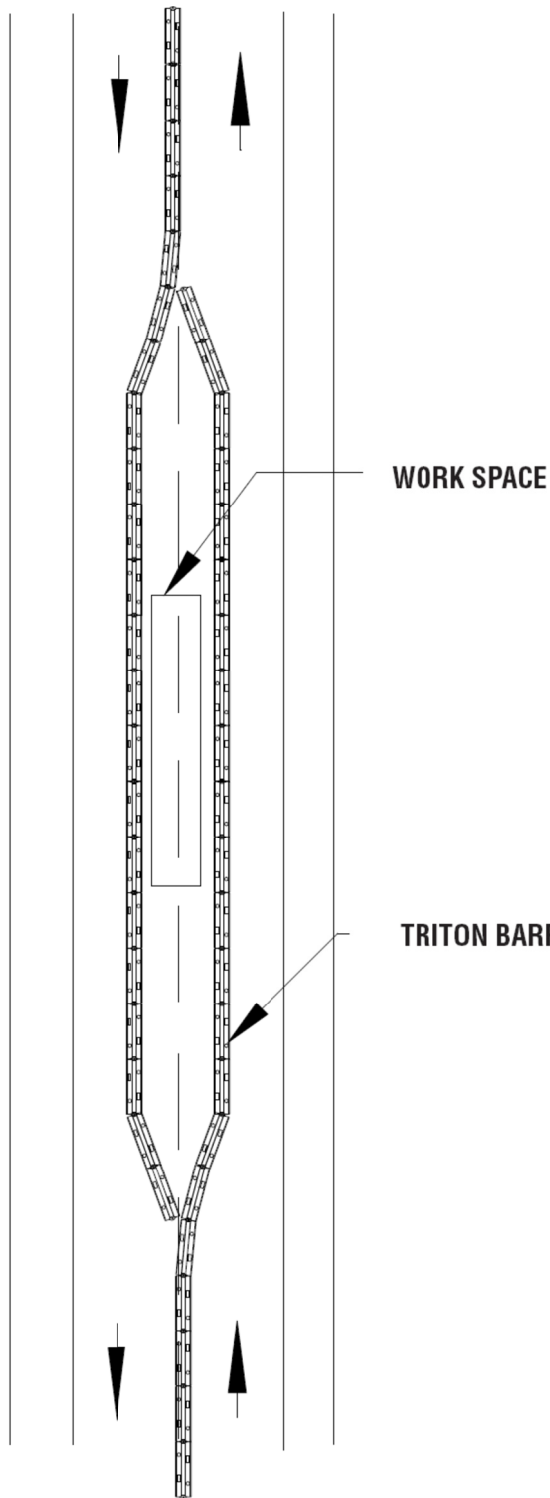

Figure 11
Work in Center of Low-Volume Road
 (Similar to TA-15 of MUTCD Part 6)

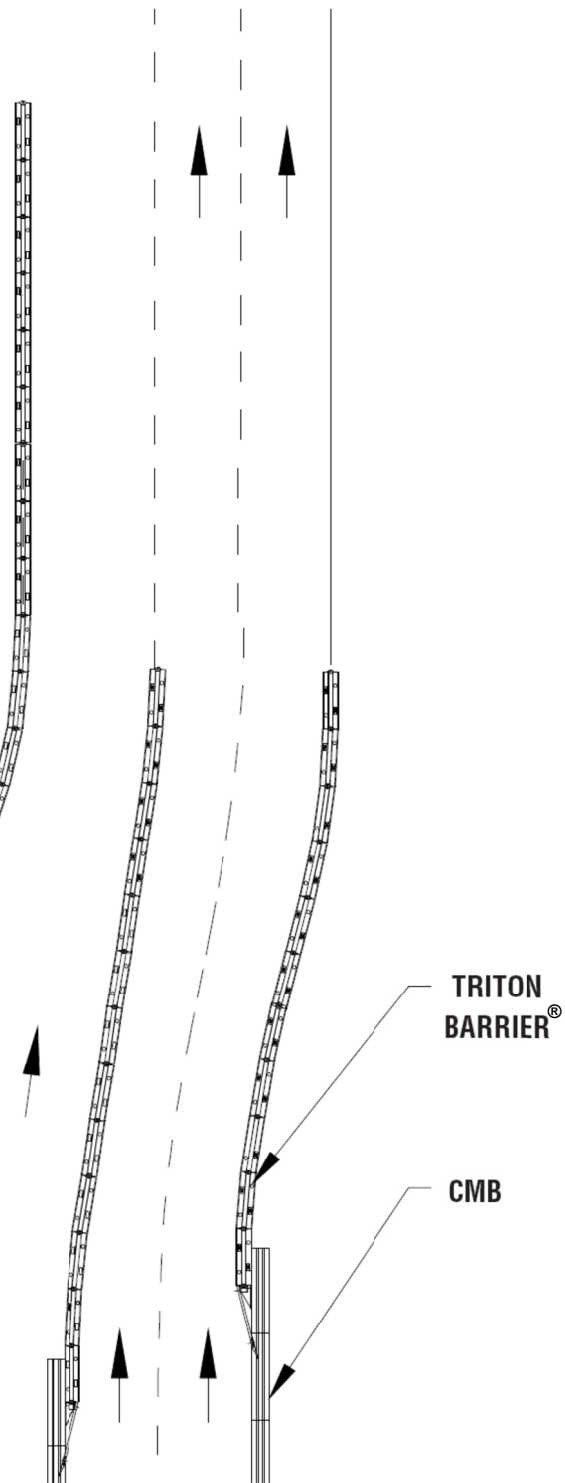

Figure 12
Typical Transition and End Treatment

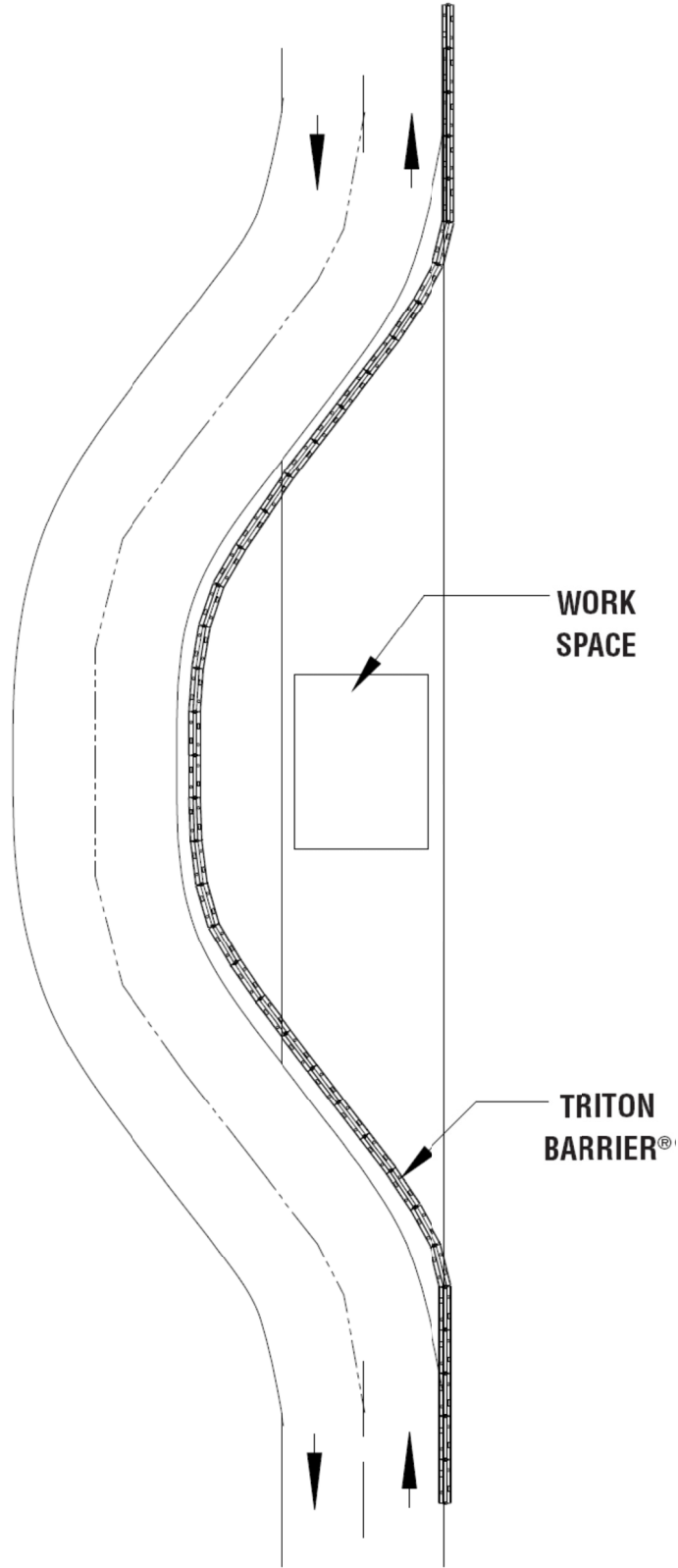

Figure 13
Typical Transition and End Treatment

Length of Need

Length of need (L.O.N.) is defined as the total length of a longitudinal barrier needed to shield an area of concern (1). It is also described as that part of a longitudinal barrier or terminal intended to contain and redirect an errant vehicle (2).

Triton Barrier® TL-3

100 km/h [62 mph]

The Triton Barrier® TL-3 End Treatment is 40 m [130'] and is 20 sections long. The Beginning of Length Of Need (B.L.O.N.) is 20 m [65'], which is 10 sections from the end of the Triton Barrier® TL-3 (See Figure 14). The minimum length needed for Triton Barrier® TL-3 is 60 m [200'] and requires 30 sections (See Figure 15).

- 1) AASHTO Roadside Design Guide, 2011
- 2) NCHRP 350

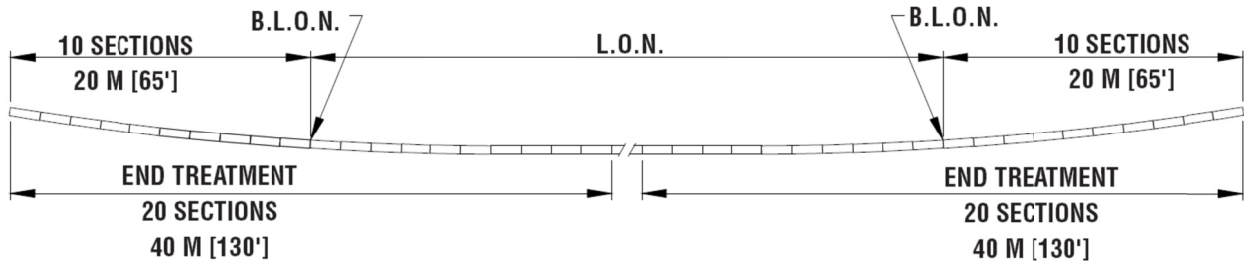

Figure 14
Triton Barrier® TL-3 L.O.N. For
Unidirectional or Bidirectional Traffic

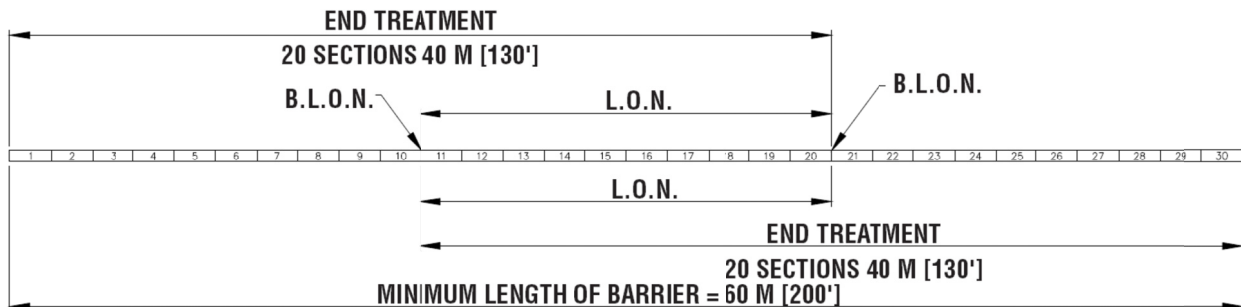

Figure 15
Minimum Length Layout for Triton Barrier® TL-3

Triton Barrier® TL-2

70 km/h [45 mph]

The Triton Barrier® TL-2 End Treatment is 20 m [65'] and is 10 sections long. The Beginning of Length Of Need (B.L.O.N.) is 10 m [33'] and is five sections from the end of the Triton Barrier® TL-2 (See Figure 16). The minimum length needed for Triton Barrier® TL-2 is 30 m [100'] and requires 15 sections (See Figure 17).

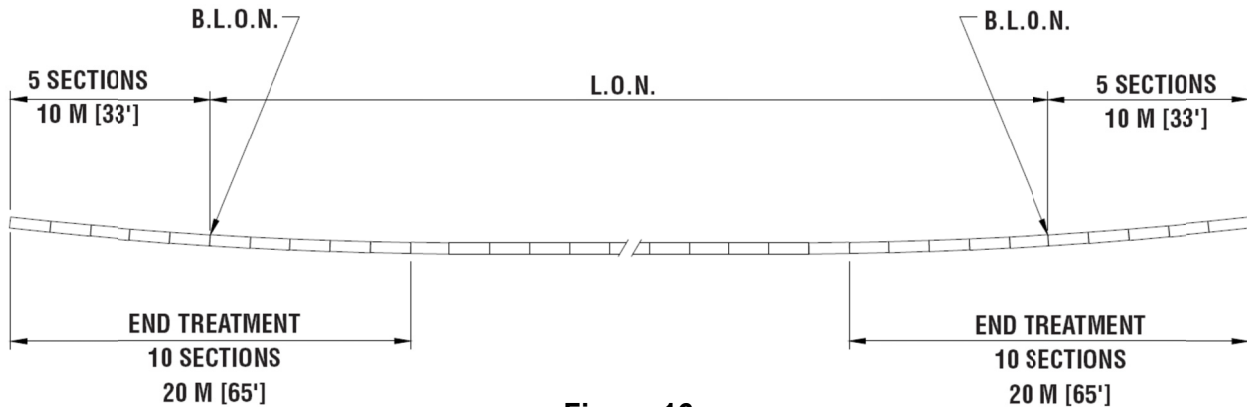

Figure 16
Triton Barrier® TL-2 L.O.N. For
Unidirectional or Bidirectional Traffic

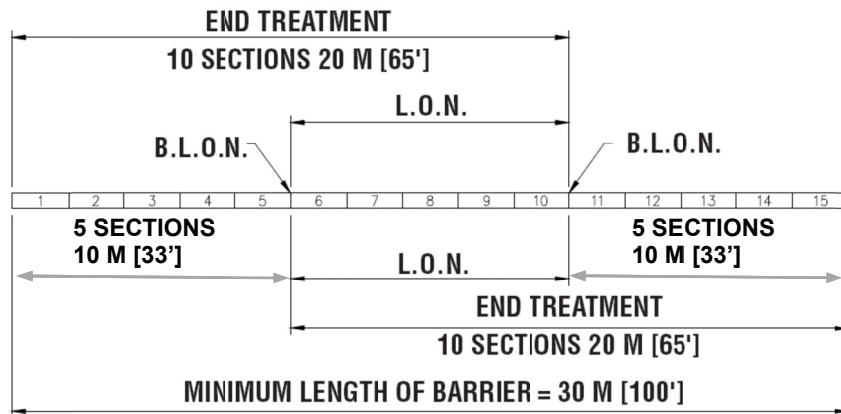

Figure 17
Minimum Length Layout for Triton Barrier® TL-2

Triton Barrier® TL-1

50 km/h [31 mph]

The Triton Barrier TL 1 End Treatment is 30m [100'] and is 15 sections long. The Beginning of Length of Need (B.L.O.N.) is 10m [33'] and is five sections from the end of the Triton Barrier TL-1 (See Figure 17a).

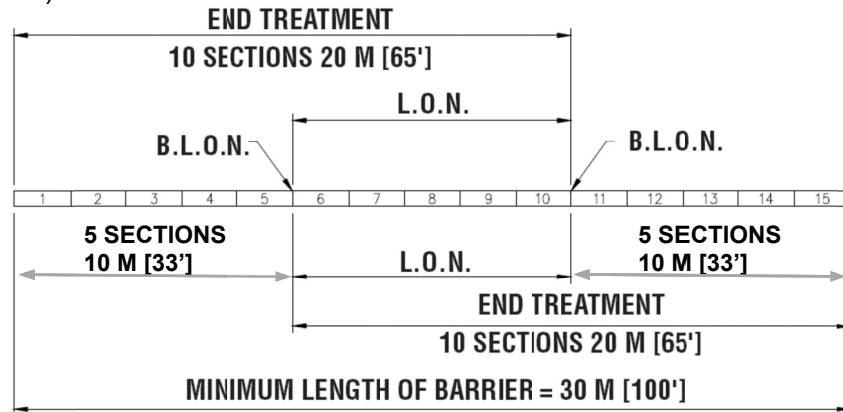

Figure 17a
Triton Barrier® TL-1 L.O.N. For
Unidirectional or Bidirectional Traffic

Deflection/Clear Zone

To determine the expected deflection, refer to Figure 17b and determine the value for S (in feet) for the site in question. S is the perpendicular distance from the face of the barrier out to the nearest side of a reference vehicle (a 3/4 ton pickup truck) which is driving exactly in the center of the lane furthest from the barrier.

The clear zone must allow for the deflection of the Triton Barrier®.

Except for an anchored ridged barrier, all barriers will experience some amount of deflection.

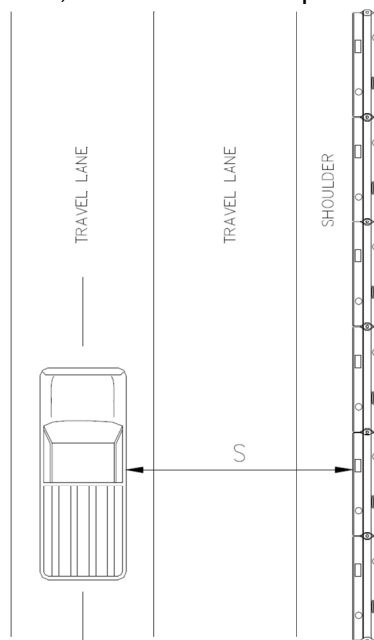

Figure 17b
Using S, refer to the Figure 17c to determine the
Expected Deflection (in feet).

Triton Barrier® Expected Deflection Ranges

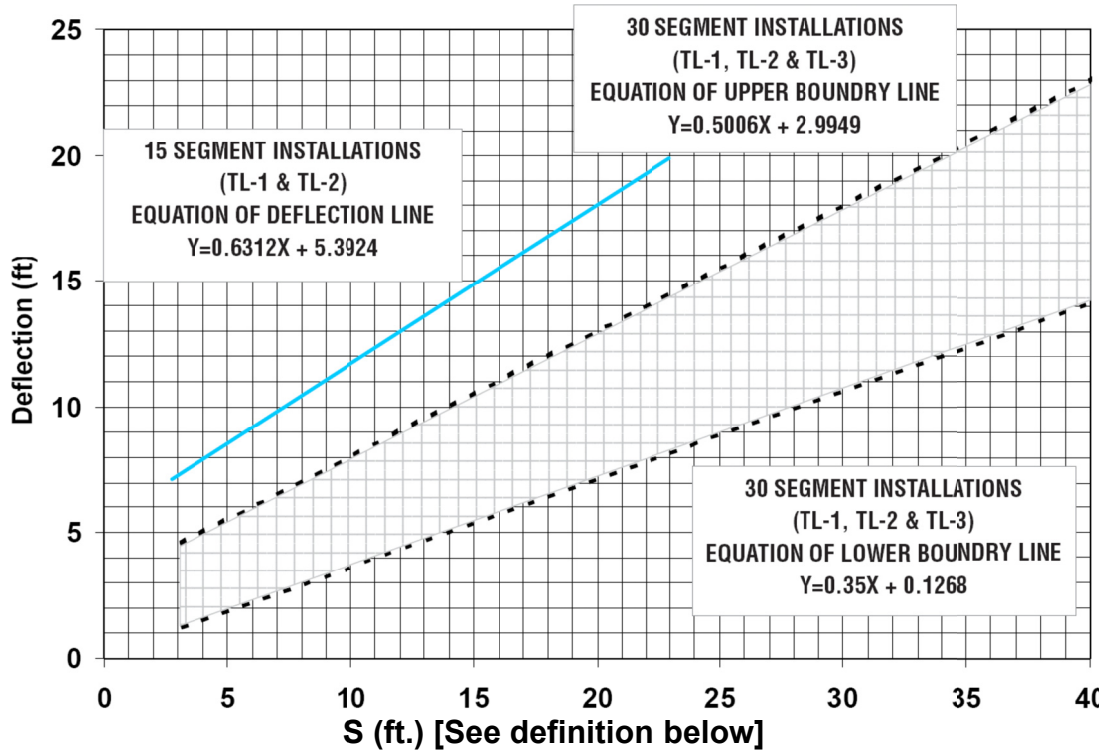

Figure 17c

Definition:

S is the perpendicular distance from the face of the barrier out to the nearest side of a reference vehicle (a 3/4 ton pickup truck) that is driving exactly in the center of the lane farthest from the barrier (See Figure 15 on Page 16).

End Treatment

TL-3 100 km/h [62 mph]

The Triton Barrier® TL-3 has been thoroughly tested to NCHRP 350 TL-3 Non-Redirective Gating conditions. The End Treatment has also been thoroughly tested for 100 km/h [62 mph] when assembled as shown to the NCHRP 350 standard.

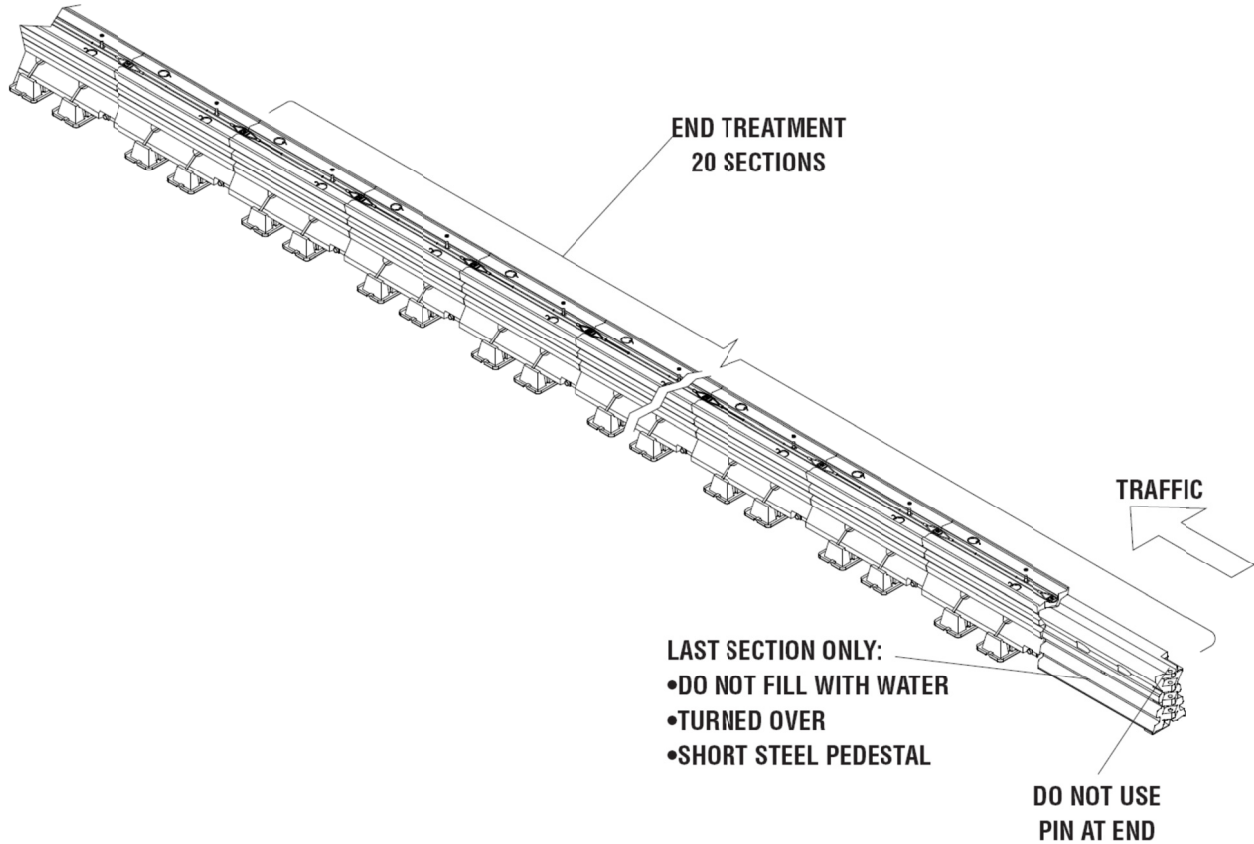

Figure 18
Triton Barrier® TL-3 End Treatment

TL-2 70 km/h [45 mph]

The Triton Barrier® TL-2 has been thoroughly tested to NCHRP 350 TL-2 Non-Redirective Gating conditions. The End Treatment has also been thoroughly tested for 70 km/h [45 mph] when assembled as shown to the NCHRP 350 standard.

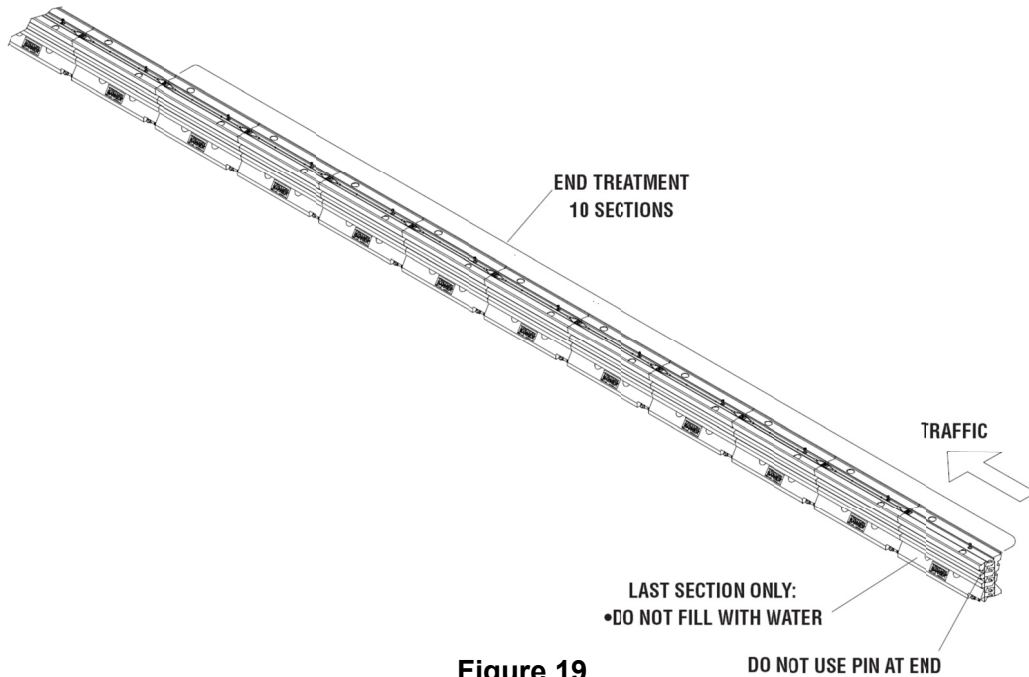

Figure 19
Triton Barrier® TL-2 End Treatment

TL-1 50 km/h [31 mph]

The Triton Barrier® TL-1 has been thoroughly tested to NCHRP 350 TL-1 Non-Redirective Gating conditions. The End Treatment has also been thoroughly tested for 50 km/h [31 mph] when assembled as shown to the NCHRP 350 standard.

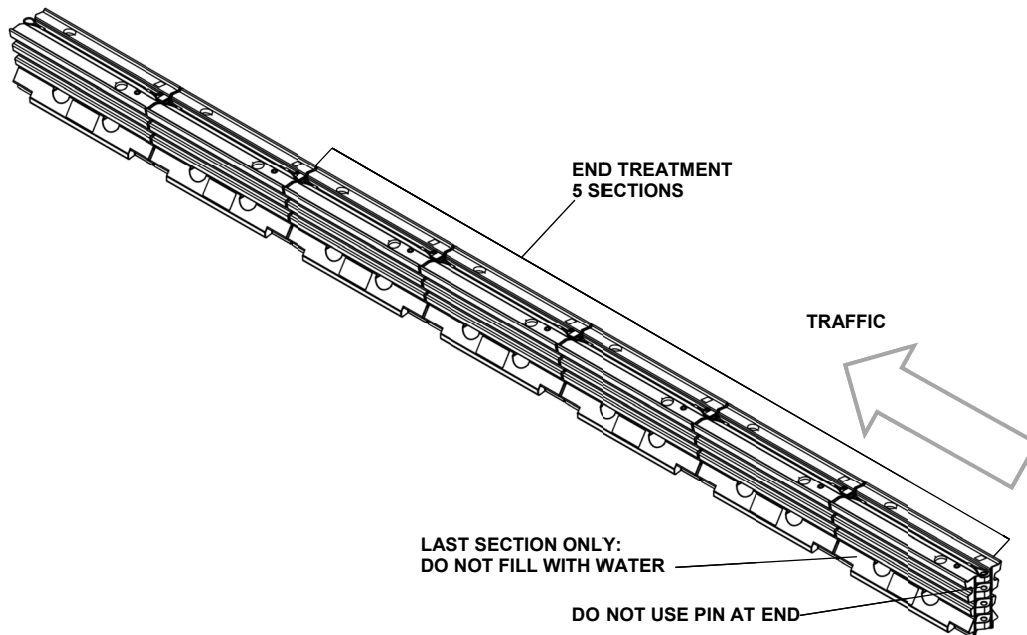

Figure 19
Triton Barrier® TL-1 End Treatment

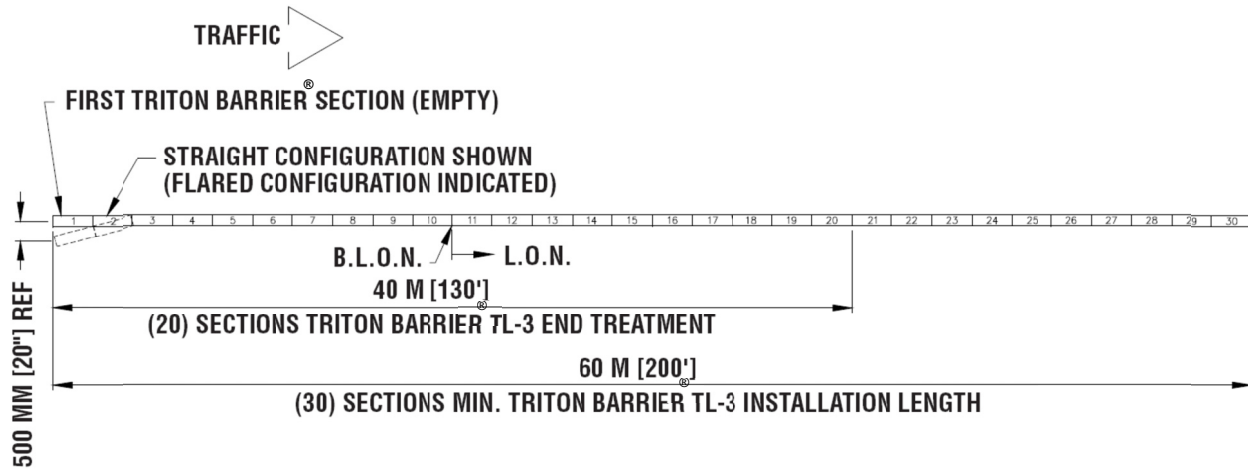

Figure 20
Triton Barrier® TL-3 End Treatment Placement 100 km/h [62 mph]

Notes:

1. Fill all sections except the first section with water. First section is to be upside down. Do not use a connecting pin on the exposed end of the first section.
2. Vehicle trajectory will be biased toward the flare side of a flared configuration.
3. All sections are to have Pedestals strapped to the bottom. The first section uses a Short Steel Pedestal.

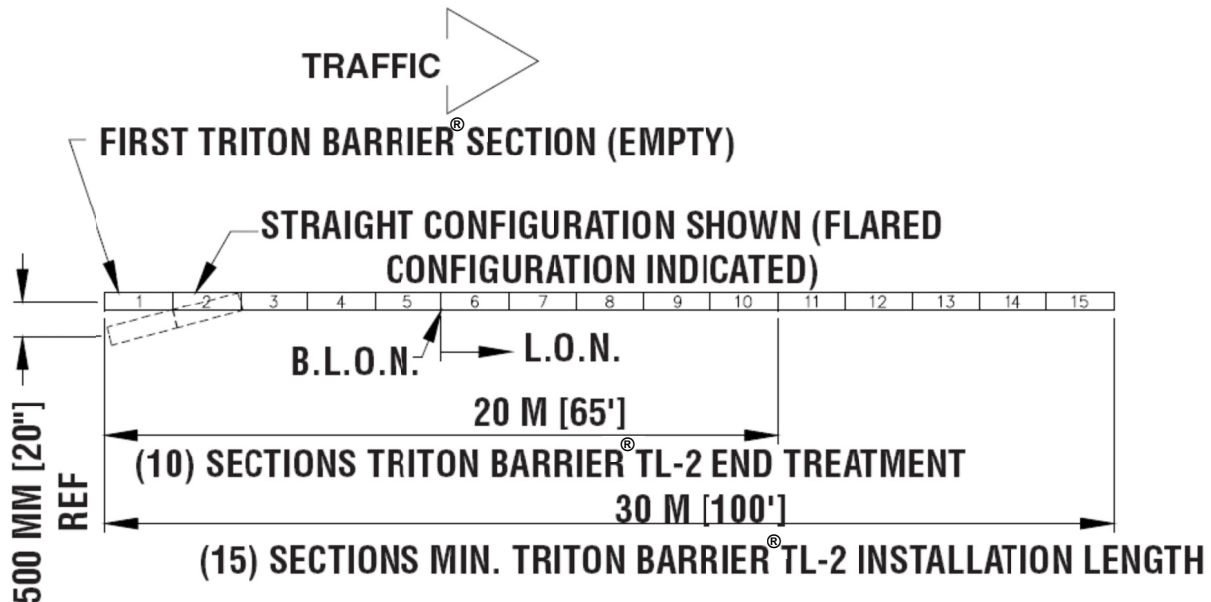

Figure 21
Triton Barrier® TL-2 End Treatment Placement 70 km/h [45 mph]

Notes:

1. Fill all sections except the first section with water. Do not use a connecting pin on the exposed end of first section.
2. Vehicle trajectory will be biased toward the flare side of a flared configuration.



TRAFFIC 

**Figure 22
STRAIGHT**

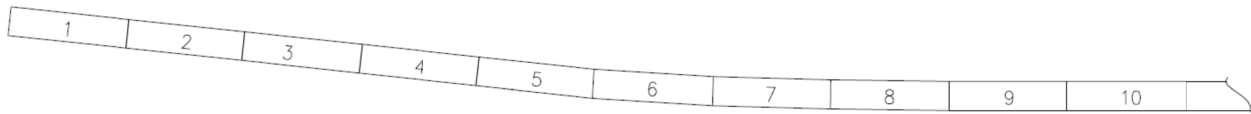

TRAFFIC 

**Figure 23
FLARED**

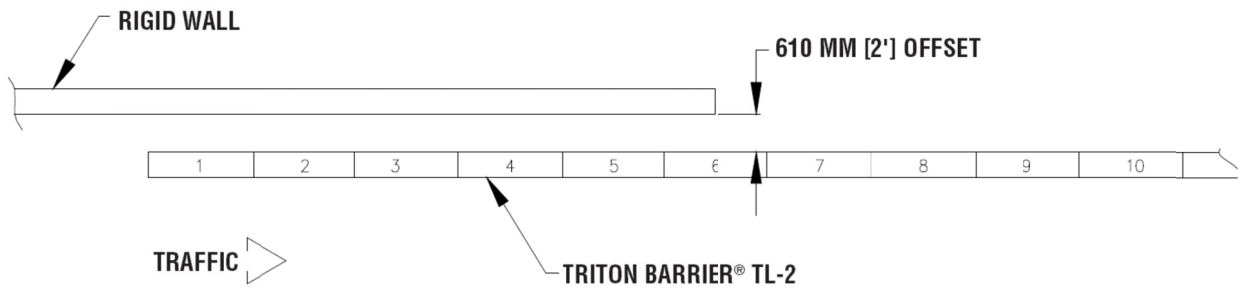

**Figure 24
OFFSET**

End Treatment Configuration

When Triton Barrier® TL-2 is used in conjunction with other longitudinal barriers, End Treatments and/or Transitions are necessary. Several different options are available. Consider the following:	Barrier Location
	- Roadside
	- Median
	- Other
Longitudinal Barrier Type	
- W-Beam Guardrail	Taper Angle
- Thrie Beam Guardrail	- Straight
- PCMB	- Maximum Flare
- CMB	Traffic Direction
- Vertical Wall	- Unidirectional
- Other	- Bidirectional

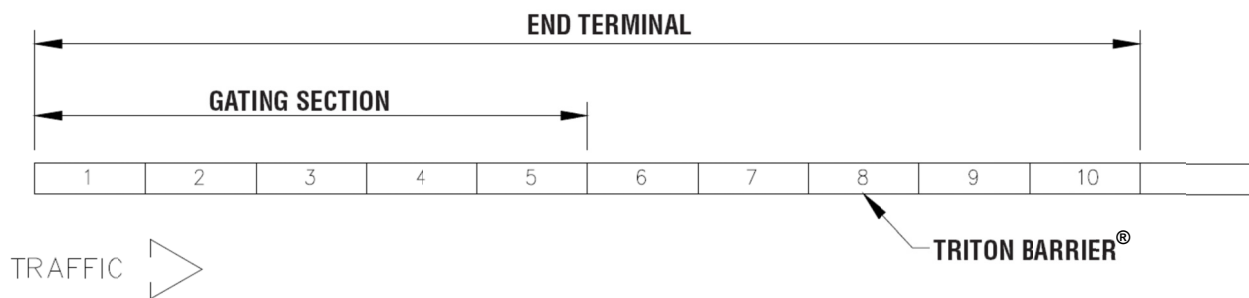

Figure 25
Free Standing Triton TL-2 End Treatment

Refer to Figures 25 through 31 for appropriate uses of Triton Barrier®.

In the application, the Triton Barrier® TL-2 acts as its own impact appropriate, non-redirective TL-2 End Treatment. The system can stand alone with no extra hardware in areas where no obstacles are present. The first five sections allow vehicles to gate through. Sections six through ten have greater deflection than the mid region. See Deflection/Clear Zone for more information.

In the application, the Triton Barrier® TL-2 can be placed against rigid barrier. It will act as an appropriate End Treatment for impact when the first five sections are placed at 610 mm [2'] minimum offset.

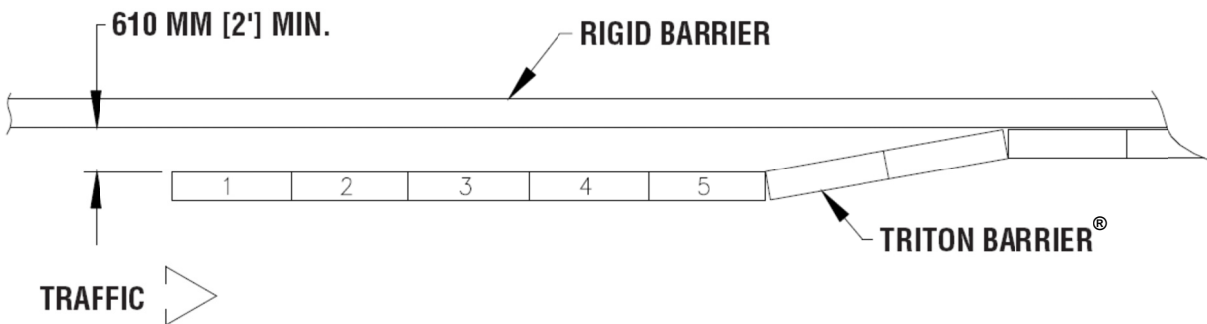

Figure 26
Triton TL-2 End Treatment Along Side Rigid Barrier

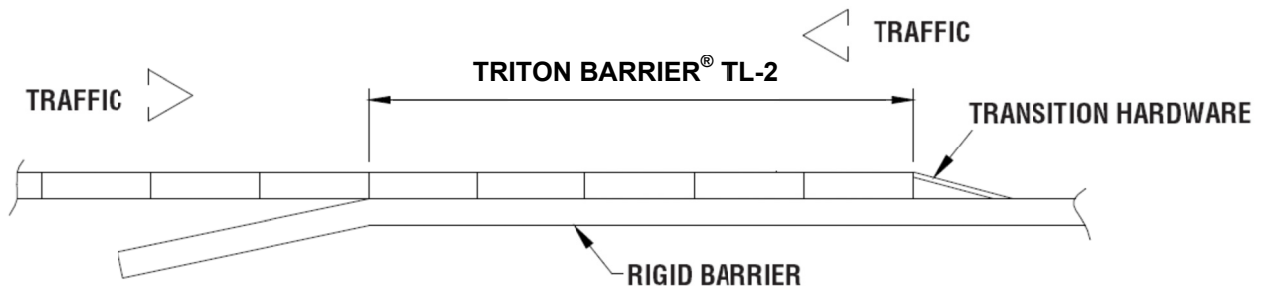

Figure 27
Triton Barrier® TL-2 Against Flared Rigid Barrier

For traffic direction shown here, flare rigid barrier to prevent pocketing. If used in two way traffic where cross-over traffic is a concern, transition hardware is recommended. Five sections must be overlapped.

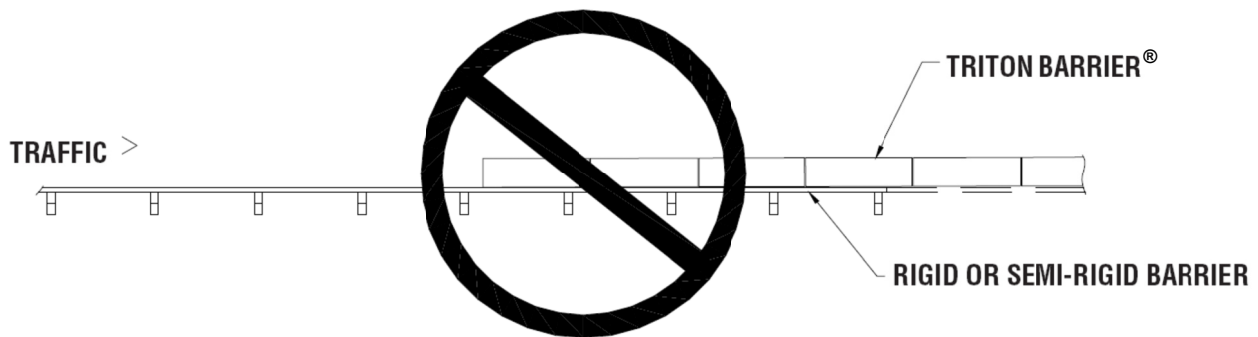

Figure 28

Do **NOT** place end of Triton Barrier® (TL-2 or TL-3) directly against rigid or semi-rigid barrier.

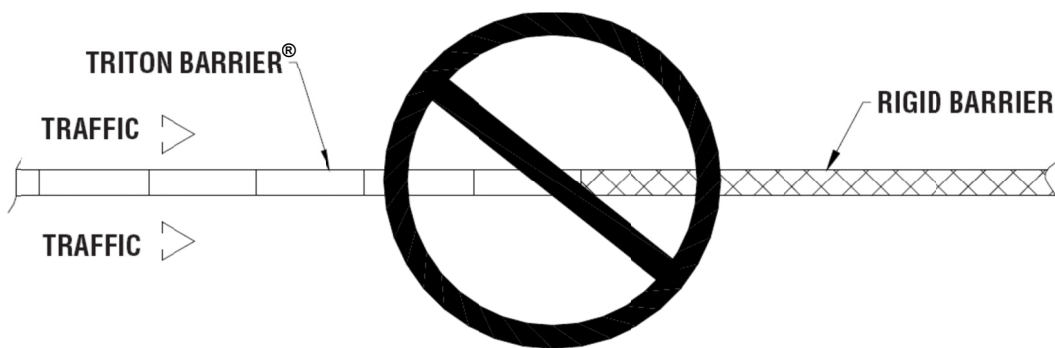

Figure 29

Triton Barrier® (TL-2 or TL-3) is **NOT** an End Treatment for rigid barrier. It is only to be used as a terminal to terminate Triton Barrier®.

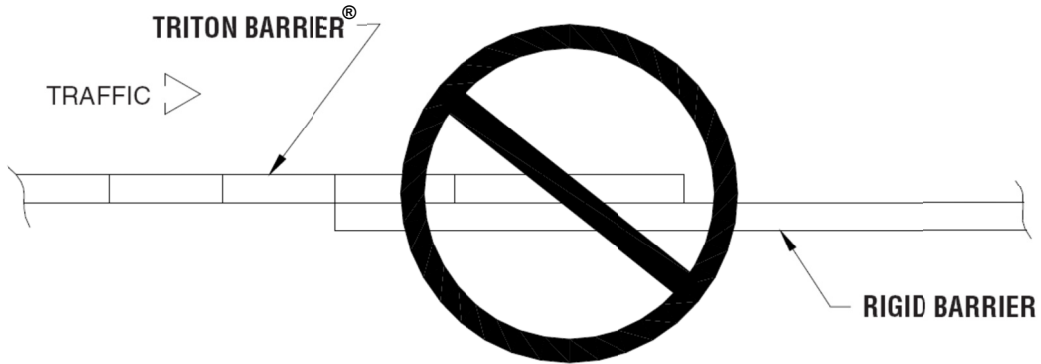

Figure 30

Do **NOT** use Triton Barrier[®] (TL-2 or TL-3) against approach end of rigid barrier (Figure 33) unless rigid barrier is flared as show in Figure 27.

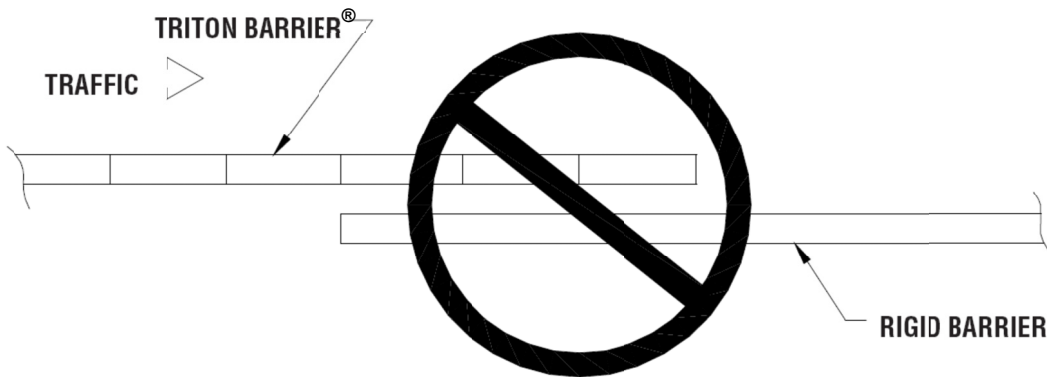

Figure 31

Do **NOT** use Triton Barrier[®] (TL-2 or TL-3) alongside approach end of rigid barrier unless rigid barrier is flared as shown in Figure 30.

Other Considerations

Certain conditions may affect the performance of the Triton Barrier[®] (TL-2 or TL-3). Since every job site is unique the designer needs to consider the following conditions to see if they apply.

Curves

The ends of each section are constructed with knuckles that interlock with those of other segments. The End Knuckles are vertically aligned to accept a Steel Connecting Pin. The pin securely joins the Sections and Tension Cables to achieve performance of the system under appropriate state and federal guidelines. The sections can swivel at the pin for easy positioning around work areas. The sections can be positioned with an inside radius as small as 11.3 m [37"] (See Figure 32).

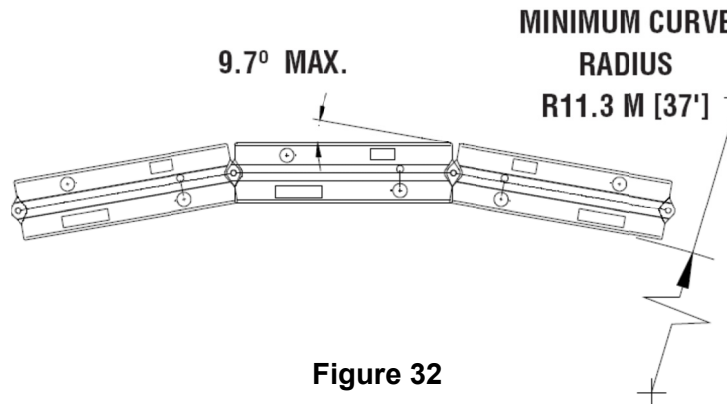

Figure 32

Slopes

Cross Slopes

The Triton Barrier[®] may be placed on cross slopes up to 5% or 3 degrees (See Figure 33).

Longitudinal slopes

The Triton Barrier[®] may be placed on longitudinal slopes up to 5% or 3 degrees (See Figure 34).

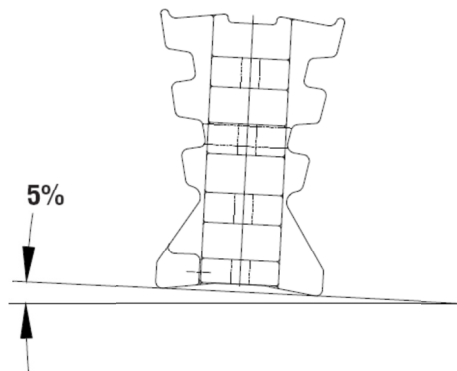

Figure 33

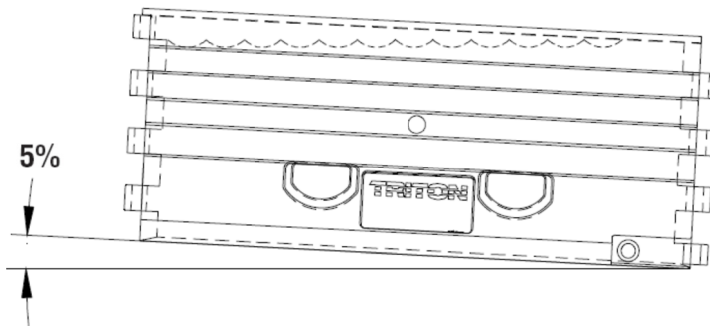

Figure 34

Hills

The Triton Barrier[®] has the potential to conform to a hill up to 20:1. Please note the maximum longitudinal slope in Figure 34.

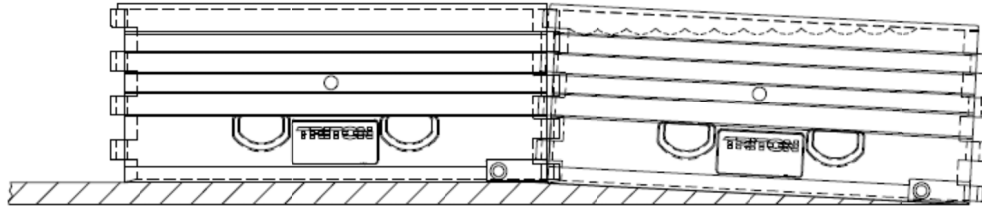

Figure 35

Ditch

The Triton Barrier[®] has the potential to conform to a ditch up to 20:1. Please note the maximum longitudinal slope in Figure 34.

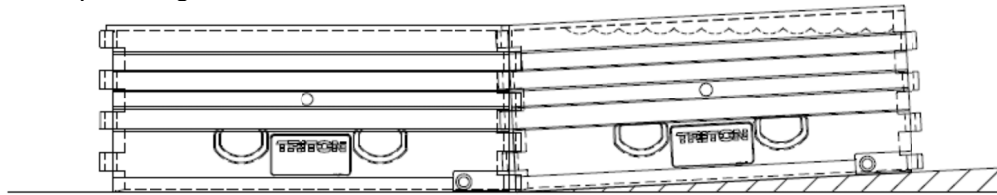

Figure 36

Curbs

Triton Barrier[®] shall **NOT** be placed directly against curbs that can prevent its lateral movement.

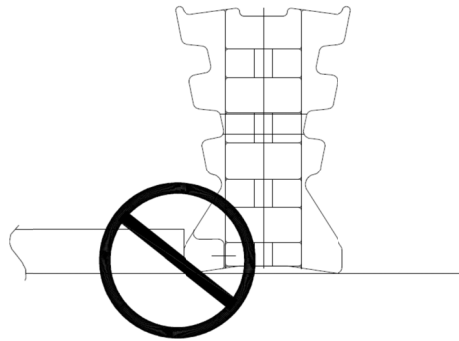

Figure 37

Taper

Recommended maximum taper angle:

70 km/h [45 mph] – 9:1 (6 degrees)

100 km/h [60 mph] – 13:1 (4 degrees)

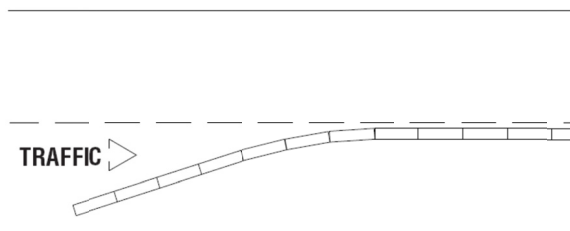

Figure 38

Environmental Considerations

Storing Empty Triton Barrier® When Freezing is Expected

To maintain Triton Barrier® portability, it is best not to let water enter the system and freeze. Possible solutions are to cover the sections with a waterproof tarp, leave the Gate Valves partially open to allow drainage or store the sections upside down being careful not to damage the water level floats.

Using Triton Barrier® When Freezing is Expected

The Triton Barrier® system has successfully passed full scale impact testing when frozen. Triton Barrier® was also subjected to freeze/thaw cycles with successful results. When frozen, the expansion of the water created bulges in the Triton Barrier® that return to the original shape when thawed. The Triton Barrier® would sometimes rock to one side due to the bulges when frozen. To prevent the formation of bulges and the subsequent rocking, antifreeze may be added to the water.

Another solution is to add antifreeze to the end sections (2-6) and every 10th Barrier (See Figure 40). This method will keep the Barrier upright and cut down on the expense of antifreeze.

Available Antifreeze

- SALT (Sodium Chloride) – 20% solution by weight protects to 0 deg. F. Low cost. Corrosive. Needs to be premixed and large spills may be harmful to vegetation.
- Calcium Chloride – 35% solution by weight protects to -20 deg. F. Medium cost. Corrosive to zinc. Large spills may be harmful to vegetation and spills may be slick. A significant amount of heat is generated during mixing which may require mixing before placing in the barrier.
- Ethylene Glycol - 50% solution by volume protects to -20 deg. F. Medium to high cost. Large spills should be considered dangerous due to potential for environmental harm. Spills may also be slick.
- Propylene Glycol – 50% solution by volume protects to -20 deg. F. High cost. Large spills may be harmful to vegetation and spills may be slick.
- Liquid CMA (calcium magnesium acetate) – 25% solution by volume protects to 0 deg. F. Very high cost. Considered environmentally safe and nontoxic.
- Liquid Potassium Acetate – 60% solution by volume protects to -20 deg. F. Extremely high cost. Considered environmentally safe and nontoxic.

Notes:

1. The water/antifreeze mixture should be returned to the water truck and recycled for environmental reasons and cost of antifreeze.
2. For those mixtures that may be slick, the solution should be washed away with large amounts of water and the area should be sanded to prevent skidding if large spill would occur.
3. Regardless of which antifreeze is chosen, the user should check with local ordinances relative to environmental issues.
4. To minimize corrosion of galvanized steel frames, keep segments full of chloride solution. If drained, thoroughly rinse and dry frame.

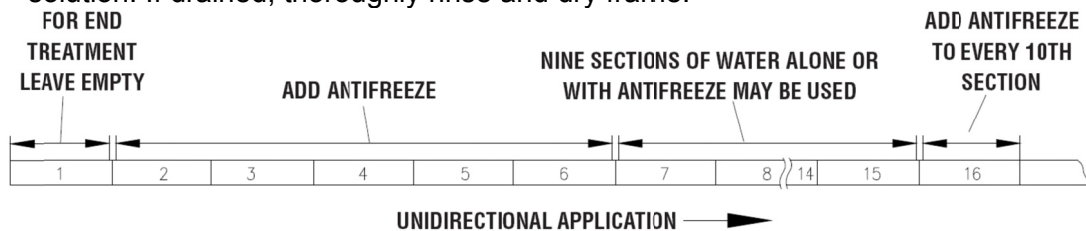

Figure 39

Notes:



2525 Stemmons Freeway

Dallas, Texas 75207

888-323-6374 (USA only)

312-467-6750 (Outside USA)

www.energyabsorption.com

www.highwayguardrail.com